

| ITEM | QTY | P/N | DESCRIPTION |
|------|-----|------------------|---------------------------------|
| 1 | 1 | CLE7625UHT-13 | ASSEMBLY, TONG, 7-5/8" 30k |
| 2 | 1 | MKBUCT7625-CM | ASSEMBLY, MOUNTING KIT |
| 3 | 1 | BUCT8625 | ASSEMBLY, BACKUP 8 5/8" |
| 4 | 1 | VP7625UHT-535SAE | ASSEMBLY. VALVE PACKAGE |
| 5 | 1 | CM7625-01 | ASSEMBLY, CHROMEMASTER™, 7-5/8" |

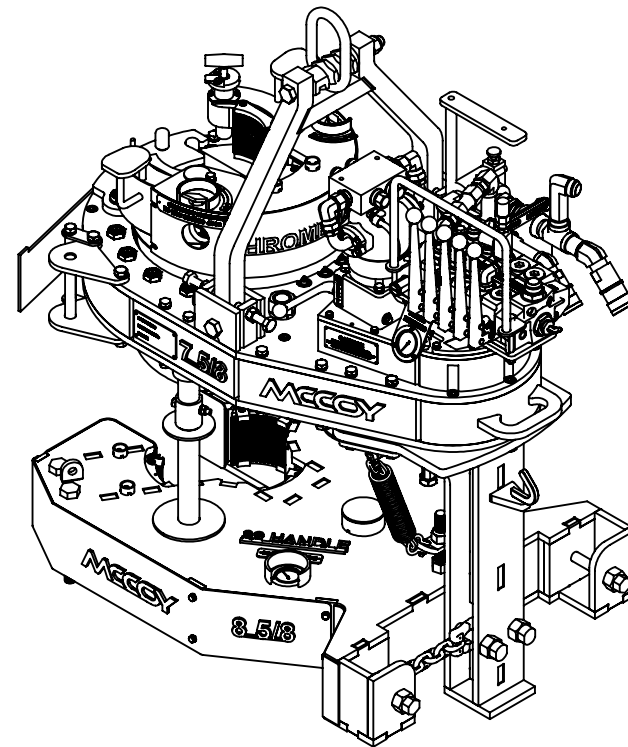

| TONG SPECIFICATION | | |
|--------------------------------|-------|-------|
| MAX TORQUE (FT-LBS/N-M) | 30000 | 40700 |
| TONG ARM LENGTH (INCH/CM) | 37.3 | 94.7 |
| BACKUP HANDLE LENGTH (INCH/CM) | 32.0 | 81.28 |
| WEIGHT (LBS/KG) | 3500 | 1600 |
| TORQUE (FT-LBS/N-M ESTIMATED) | | |
| AT PRESSURE (PSI/BAR) | 2700 | 186 |
| HI/FULL | 4300 | 5800 |
| LO/FULL | 30000 | 40700 |
| SPEED (RPM, ESTIMATED) | | |
| AT FLOW RATE (GPM/LPM) | 60 | 227 |
| HI/FULL | | 65 |
| LO/FULL | | 9 |

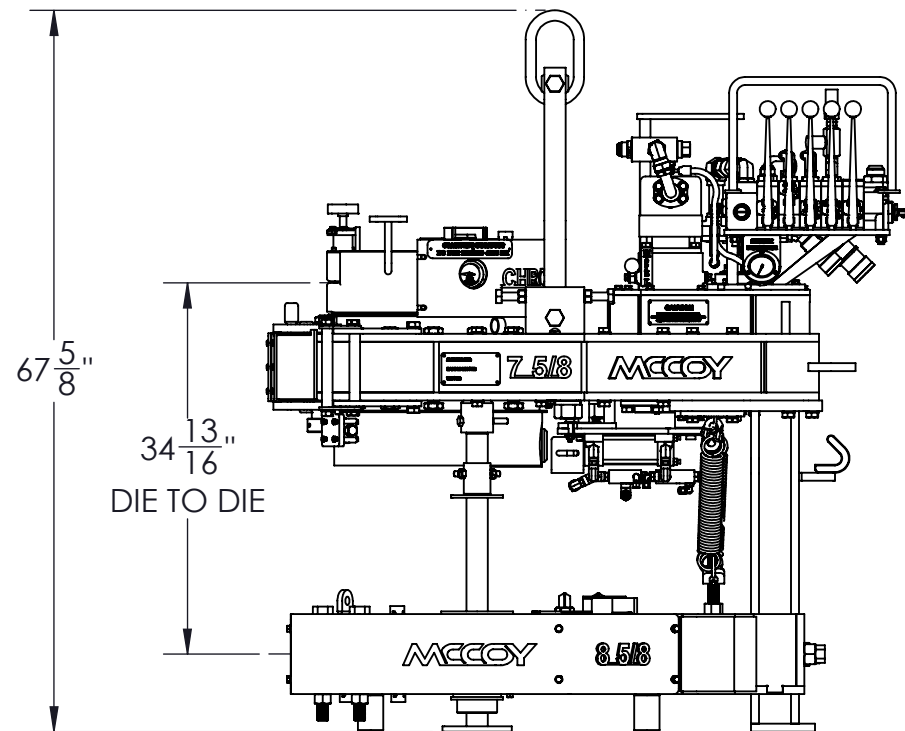

| REVISIONS | | | | |
|-----------|------------|-----------------------------|------------------|--------------------|
| REVISION | ECO NUMBER | ECO DESCRIPTION | ECO COMPLETED BY | ECO COMPLETED DATE |
| A | N/A | INITIAL RELEASE | N/A | N/A |
| B | 16-0139 | UPDATE CHARTS & DESCRIPTION | M.BUDDEN | 6/23/2016 |
| - | N/A | REMOVE TABLE | M.BUDDEN | 1/23/2018 |

| UNLESS OTHERWISE SPECIFIED: | | PROPRIETARY STATEMENT | | MCCOY GLOBAL | |
|---|-------------|--|--|---|--------------|
| 1. DIMENSIONS ARE IN INCHES 2. TOLERANCES: ANGULAR ± 1° FRACTIONAL ± 1/16 TWO PLACE DECIMAL ± 0.02 THREE PLACE DECIMAL ± 0.005 3. IDENTIFY P/N & MAIL P.O. USING 1/8 TO 1/4 ETCHED LETTERS, DENOTED BY "X" 4. REMOVE BURRS & SHARP EDGES WITH 1/64x45° MAX 5. MACHINED FILET RADI SHALL BE 1/32 6. FINAL SURFACE ROUGHNESS AVG. (Ra) SHALL BE ≤ 250 MICROINCHES 7. CRITICAL DIMENSIONS SHALL BE INSPECTED TO 100% 8. A TRIANGLE DENOTES A REVISION 9. INTERPRET DRAWING PER ASME Y14.5-2009 | | THIS DOCUMENT IS THE PROPERTY OF MCCOY CORPORATION AND IS CONSIDERED CONFIDENTIAL. THIS INFORMATION MAY NOT BE USED, DISCLOSED, COPIED, OR REPRODUCED IN ANY FORM, WITHOUT THE EXPRESS WRITTEN CONSENT OF MCCOY CORPORATION. | | DESCRIPTION ASSEMBLY, TONG, 7625-30K X 8625 CLINCHER BU, TENSION, CM | |
| DRAWN | S.McCROSKEY | 05/27/2015 | CHECKED | M.BUDDEN | 05/27/2015 |
| APPROVED | M.BUDDEN | 05/27/2015 | SIZE PART NO. 80-760-30C-86T-000-50-00 | | |
| THIRD ANGLE PROJECTION | | | WEIGHT 3474.2 LBS. | | MATERIAL N/A |
| | | | | | REV B |
| | | | | | SHEET 1 OF 1 |

RELEASED FOR PRODUCTION