

TONG SPECIFICATION		
MAX TORQUE (FT-LBS/N·M)	35,000	47,460
ARM LENGTH (INCH/CM)	36.0	91.4
MASS (LBS/KG)	1,600	726
TORQUE (FT-LBS/N·M, ESTIMATED)		
AT PRESSURE (PSI/BAR):	2,500	172
Hi/Full	7,000	9,492
Lo/Full	35,000	47,460
SPEED (RPM, ESTIMATED)		
AT FLOW RATE (GPM/LPM):	60	227
Hi/Full	45.6	
Lo/Full	9.1	

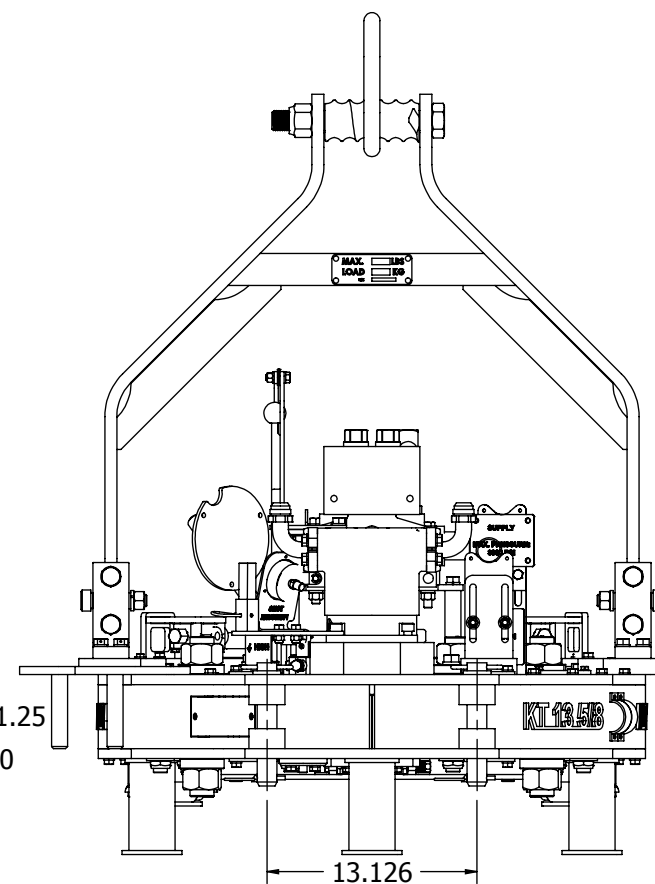

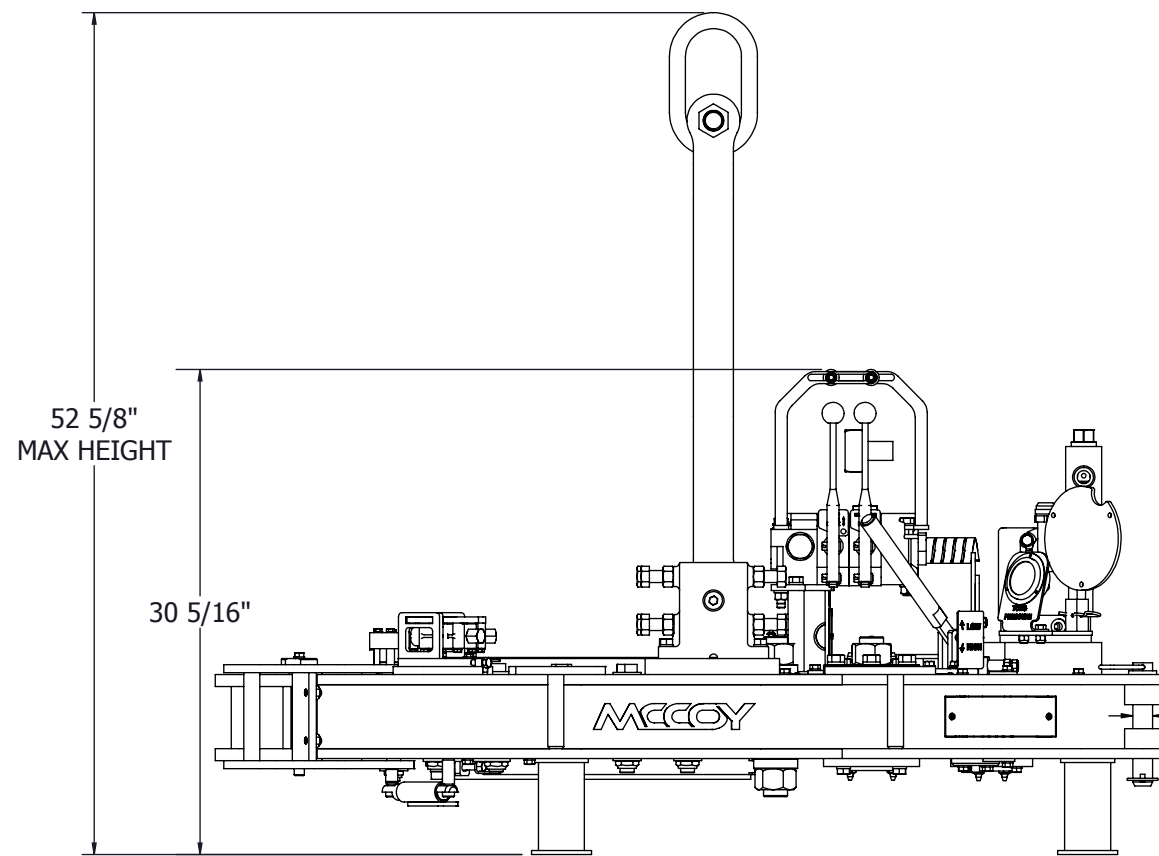

REVISIONS				
REVISION	ECN NUMBER	ECN DESCRIPTION	ECN COMPLETED BY	ECN COMPLETED DATE
2	002272	REMOVED 101-1742-CE(X1), 02-0516(X1), 1053-1-H(X1), 1053-C-1L(X4), 101-1361(X1), 101-1364(X1), 1053-C-1C(X2), 101-6221(X4), 101-6080(X4) & CE-HANDLE-2(X1), ADDED 101-6860(X1) & 101-6861(X1), ARMLENGTH 36.0" WAS 36.6"	SP	10/APR/2014
A	ECN-16-0157	REMOVED 101-6122 (X1) ADDED CE-PRESSUREMNT (X1), 1500-09-03A (X1) & 101-8087(X1)	SP	25/07/2016
B	ECN16-0235	ADDED ORIFICE 1429-512-01, CHECK VALVE 02-9022, ORB PLUG 10-9001 AND REPLACED PRESSURE RELIEF 10-0062 WITH 10-0084	T.YIMER	11/4/2016
C	ECN17-0075	ADDED 02-9022 (X1)	S. PANCHAL	3/31/2017
D	ECN17-0132	101-9251 WAS 1500-09-04A, 1483-500-00-07 WAS CE-PRESSUREMNT, UPDATED FASTENERS	S.YUAN	06/13/2017
-	N/A	REMOVE TABLE	R. HENRY	1/18/2018

UNLESS OTHERWISE SPECIFIED:		PROPRIETARY STATEMENT		DESCRIPTION	
1. DIMENSIONS ARE IN INCHES	2. TOLERANCES:	THIS DOCUMENT IS THE PROPERTY OF MCCOY CORPORATION AND IS CONSIDERED CONFIDENTIAL. THIS INFORMATION MAY NOT BE USED, DISCLOSED, COPIED, OR REPRODUCED IN ANY FORM, WITHOUT THE EXPRESS WRITTEN CONSENT OF MCCOY CORPORATION.			
ANGULAR ± 1°	FRACTIONAL ± 1/16	DRAWN	MRM	05/19/2010	ASSEMBLY, TONG, 13625-35K, NO BU
TWO PLACE DECIMAL ± 0.02	THREE PLACE DECIMAL ± 0.005	CHECKED	DX	02/22/2011	
3. IDENTIFY P/N & MAIL P.O. USING 1/8 TO 1/4 ETCHED LETTERS; DENOTED BY "X"	4. REMOVE BURRS & SHARP EDGES WITH 1/64x45° MAX	APPROVED	DX	02/22/2011	
5. MACHINED FILET RADI SHALL BE 1/32	6. FINAL SURFACE ROUGHNESS AVG. (Ra) SHALL BE ≤ 250 MICRONS	THIRD ANGLE PROJECTION		WEIGHT	1514.08 LBS.
7. DIMENSIONS CRITICAL DIMENSION: 100% INSPECTION REQUIRED	8. A TRIANGLE DENOTES A REVISION	MATERIAL		80-0931-7	REV D
9. INTERPRET DRAWING PER ASME Y14.5-2009		SHEET 1 OF 2			

RELEASED FOR PRODUCTION

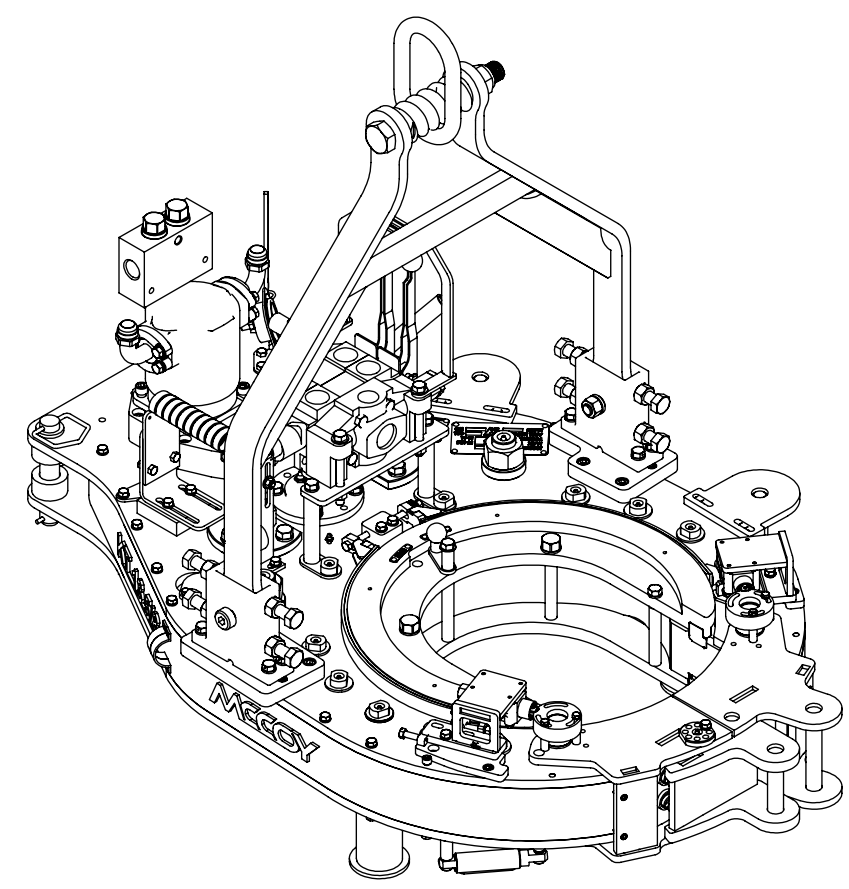
ITEM	QTY	P/N	DESCRIPTION
1	1	80-0910	ASSEMBLY, BASE TONG, 13625-35K
2	2	02-9217	FITTING, 1-1/4", SPLIT FLANGE KIT
3	3	997-D8-160A	WELDMENT, LEG
4	1	DVA35-M-S	ASSEMBLY, DVA35 VALVE
5	1	101-9251	WELDMENT, HOLDER, GAUGE
6	2	101-0011	WELDMENT, MOUNT, HYDRAULIC
7	2	02-0225	ASSEMBLY, PIN, HITCH, 1 1/4, 6 1/4
8	1	1050-C-175	ASSEMBLY, SUPPORT, COUPLING
9	1	101-0071	ASSEMBLY, SUPPORT, HYDRAULIC
10	1	997-150	MOUNT, MOTOR, HYDRAULIC
11	1	101-0727	MANIFOLD, HYDRAULIC, SAFETY DOOR
12	2	101-1268	PIN, ROLLER, BODY
13	4	101-1266	PIN, ROLLER, BODY
14	1	101-0021	BLOCK, MOUNT, HYDRAULIC
15	4	997-03	PLATE, COVER, HOLE
16	1	997-A10-149	GEAR, MOTOR
17	1	87-0112	MOTOR, HYDRAULIC, RINEER 15-15 (CID)
18	2	08-1625	CARTRIDGE, PILOT TO OPEN CHECK, LKHCXDN
19	1	08-9062	VALVE, HYDRAULIC NEEDLE
20	1	02-0981	PIN, HITCH 0.148 X 2.938
21	1	02-0006	FITTING, GREASE, 1/8 NPT, 45°
22	7	02-0097	FITTING, GREASE, 1/4-28
23	2	02-9216	FITTING, 1 1/4 CD61, 1 1/4 MJIC, ELBOW
24	1	02-0245	GAUGE, PRESSURE, FLANGE
25	1	101-5589	TAG, INLET
26	1	101-5588	TAG, RETURN
27	2	02-E0186	CLAMP, PIPE, 1
28	1	02-E0187	CLAMP, PIPE, 1 1/4
29	2	02-E0199	CLAMP, PIPE, 2"
30	1	02-E0204	WRAP, SPIRAL, OD 1.60" X ID 1.40"
31	1	101-6861	WELDMENT, VALVE GUARD
32	1	101-6860	WELDMENT, VALVE GUARD
33	2	09-1048	BOLT, HEX, 3/8-16, 1 1/4, GR 8, ZINC, FULLY THREADED
34	12	09-5106	WASHER, SPRING LOCK, REGULAR, 3/8, 17/25, 0.035-0.125, STEEL, GR 8, ZINC
35	4	09-5006	WASHER, PLAIN, FLAT, WIDE, 3/8, 1, 0.035-0.125, STEEL, ZINC
36	2	09-5806	NUT, HEX, 3/8-16, STEEL, GR 8, ZINC
37	1	01-0317	KEYSTOCK, 5/16 x 5/16, 1 1/2
38	2	09-0106	3/8-16 x 3/8
39	11	7/8	WASHER A - NARROW
40	2	09-5119	Washer, Type A, Flat, Narrow, Preferred, 1/2, 1 5/8, 0.035-0.125, STEEL, ZINC
41	2	09-1553	BOLT, HEX, 3/8-16, 1 1/2, GR 8, ZINC, FULLY THREADED
42	2	09-1046	BOLT, HEX, 3/8-16, 1, GR 8, ZINC, FULLY THREADED
43	4	09-1557	BOLT, HEX, 3/8-16, 1 3/4, GR 8, ZINC, FULLY THREADED
44	2	09-1186	BOLT, HEX, 1/2-13, 5, GR 8, ZINC, FULLY THREADED
45	6	09-2172	1/2"-13 UNC - 1-3/4"
46	1	09-2166	1/2"-13 UNC - 1"
47	1	09-2168	1/2"-13 UNC - 1-1/4"
48	7	09-5722	NUT, NYLOCK, 7/8-14 UNF, SLIM
49	1	101-8087	PLATE, MOUNTING, VALVE
50	1	1500-09-03A	WELDMENT, GAUGE, TORQUE
51	1	1429-512-01	ORIFICE, 1/32
52	1	10-0084	CARTRIDGE, RELIEF VALVE, 2001-2500 PSI
53	2	02-9022	CHECK VALVE, 1/4 NPTF
54	1	10-9001	#20 ORB PLUG WITH MACHINED #ORB PORT
55	6	09-5110	WASHER, SPRING LOCK, REGULAR, 1/2, 43/50, 0.125-0.25, STEEL, GR 8, ZINC
56	1	09-1184	BOLT, HEX, 1/2-13, 4 1/2, GR 8, ZINC, FULLY THREADED
57	3	09-9124	NUT, HEX, 1/2-13, STEEL, GR 8, ZINC
58	2	09-1168	BOLT, HEX, 1/2-13, 1 1/4, GR 8, ZINC, FULLY THREADED
59	1	1483-500-00-07	BRACKET, MOUNTING, GAUGE
60	2	09-5125	BOLT, HEX, 3/8-16, 7/8, GR 8, ZINC, FULLY THREADED
61	2	09-5607	NUT, NYLOCK, 3/8-16 UNC



DESCRIPTION			
ASSEMBLY, TONG, 13625-35K, NO BU			
SIZE	PART NO.	80-0931-7	REV
B			D
MATERIAL			SHEET 2 OF 2