

TONG SPECIFICATION		
MAX TORQUE (FT · LBS/N · M)	75,000	101,700
ARM LENGTH (INCH/CM)	45.2	114.8
MASS (LBS/KG)	3,300	1,498
TORQUE (FT LBS/N · M, ESTIMATED)		
AT PRESSURE (PSI/BAR):	2,450	169
Hi/Full	13,863	18,798
Lo/Full	75,000	101,700
SPEED (RPM, ESTIMATED)		
AT FLOW RATE (GPM/LPM):	60	227
Hi/Full	23.8	
Lo/Full	4.4	

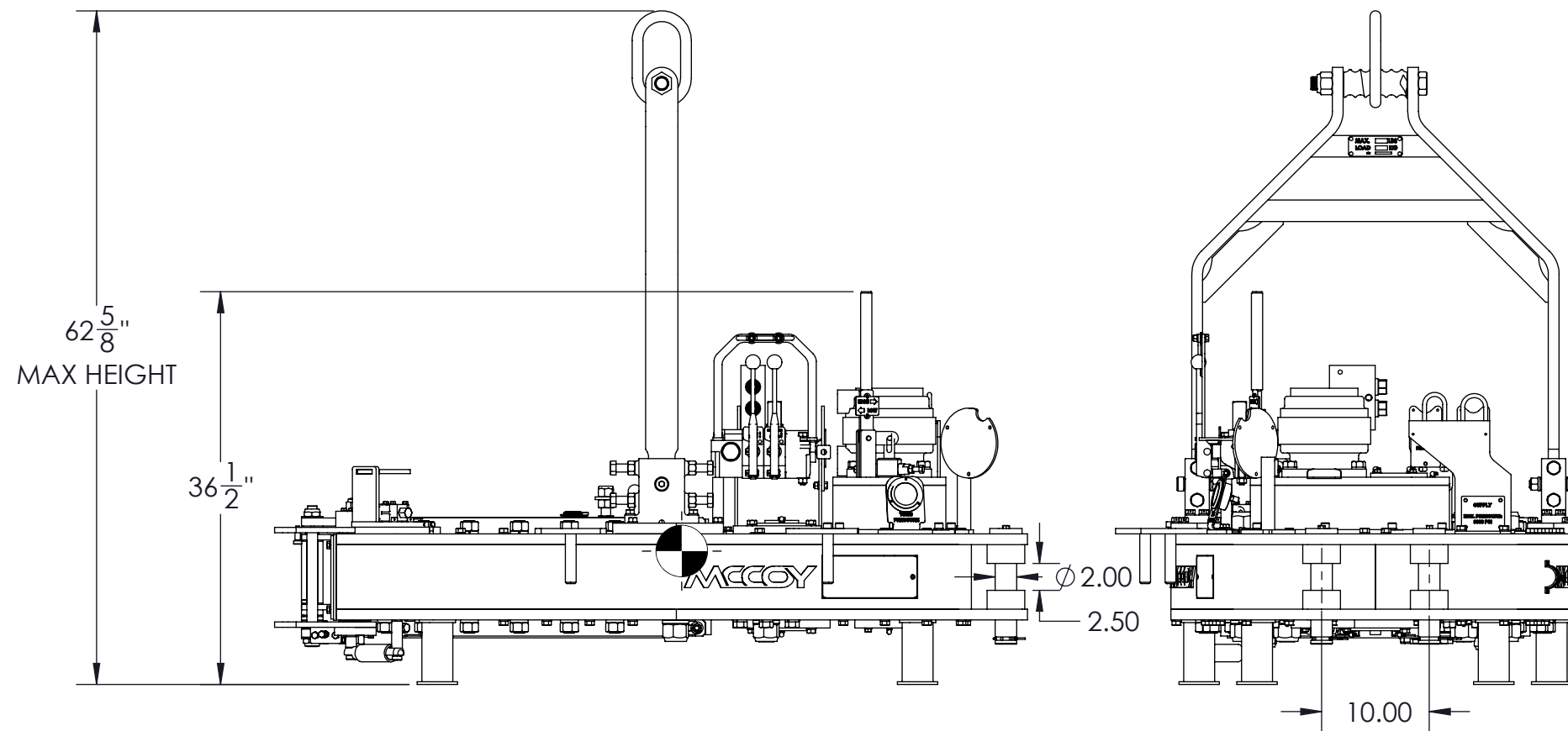

UNDER REVISION

REVISIONS				
REVISION	ECN NUMBER	ECN DESCRIPTION	ECN COMPLETED BY	ECN COMPLETED DATE
A	N/A	INITIAL RELEASE	N/A	N/A
-	N/A	REMOVE TABLE	R. HENRY	1/19/2018

UNLESS OTHERWISE SPECIFIED:		PROPRIETARY STATEMENT		DESCRIPTION	
1. DIMENSIONS ARE IN INCHES 2. TOLERANCES: ANGULAR ± 1° FRACTIONAL ± 1/16 TWO PLACE DECIMAL ± 0.02 THREE PLACE DECIMAL ± 0.005 3. IDENTIFY P/N & MAIL P.O. USING 1/8 TO 1/4 ETCHED LETTERS; DENOTED BY "X" 4. REMOVE BURRS & SHARP EDGES WITH 1/64x45° MAX 5. MACHINED FILET RADII SHALL BE 1/32 6. FINAL SURFACE ROUGHNESS AVG. (Ra) SHALL BE ≤ 250 MICROINCHES 7. DIMENSIONS IN TRIANGLES ARE CRITICAL DIMENSIONS; 100% INSPECTION REQUIRED 8. A TRIANGLE DENOTES A REVISION 9. INTERPRET DRAWING PER ASME Y14.5-2009		THIS DOCUMENT IS THE PROPERTY OF MCCOY CORPORATION AND IS CONSIDERED CONFIDENTIAL. THIS INFORMATION MAY NOT BE USED, DISCLOSED, COPIED, OR REPRODUCED IN ANY FORM, WITHOUT THE EXPRESS WRITTEN CONSENT OF MCCOY CORPORATION.		MCCOY GLOBAL ASSEMBLY, TONG, 14375-75K, CC	
DRAWN	T.YIMER	01/07/2016	SIZE PART NO.		
CHECKED	R.RAHMAN	01/25/2016	80-1001-29		
APPROVED	R.RAHMAN	01/25/2016	REV A		
THIRD ANGLE PROJECTION		WEIGHT		MATERIAL	
		3137.82 LBS.			

ITEM	QTY.	P/N	DESCRIPTION	ITEM	QTY.	P/N	DESCRIPTION
1	1	80-1000-2	ASSEMBLY, BASE TONG, 14-75K	46	6	09-1046	3/8"-16 UNC - 1"
2	1	1037-A4-144	ASSEMBLY, CYLINDER, DOOR	47	10	09-5106	WASHER, SPRING LOCK, REGULAR, 3/8, 17/25, 0.035-0.125, STEEL, GR 8, ZINC
3	1	101-5971	ASSEMBLY, SWITCH, DOOR	48	4	09-1292	SCREW, HEX, 3/4-10, 1 3/4, STEEL, GR 8, ZINC
4	1	101-5974	WELDMENT, MOUNTING, SWITCH	49	8	09-5118	WASHER, SPRING LOCK, REGULAR, 3/4, 1 17/64, 0.125-0.25, STEEL, GR 8, ZINC
5	1	101-5996	TUBE, SPACER	50	2	09-1174	BOLT, HEX, 1/2-13, 2, STEEL, GR 8, ZINC, FULLY THREADED
6	1	87-0130	MOTOR, RINEER GA37-26	51	1	02-0020	PIN, CLEVIS, 5/16 x 1
7	1	101-5951	GEAR, PINION, MOTOR	52	4	09-1286	BOLT, HEX, 3/4-10, 1, STEEL, GR 8, ZINC, FULLY THREADED
8	2	101-1442	WELDMENT, MOUNT, VALVE	53	2	09-5908	NUT, HEX, 7/16-20 UNF
9	2	101-1138	WELDMENT, COUPLING, INLET	54	2	09-1608	BOLT, HEX, 7/16-20, 1 1/4, STEEL, GR 8, ZINC, FULLY THREADED
10	1	101-1583	PLATE, SUPPORT, COUPLING	55	31	09-1172	BOLT, HEX, 1/2-13, 1 3/4, STEEL, GR 8, ZINC, FULLY THREADED
11	1	101-0022	PLATE, COUPLING, OUTLET	56	1	101-6861	WELDMENT, VALVE GUARD
12	1	DAV35-M-S-B	ASSEMBLY, DVA35 VALVE	57	1	101-6860	WELDMENT, VALVE GUARD
13	1	101-1806	WELDMENT, MOUNT, PIPE	58	1	101-2865	MOUNT WELDMENT, TORQUE GAUGE, KT 8625 BJ
14	1	101-2075	U-BOLT	59	1	1483-500-00-07	BRACKET, MOUNTING, GAUGE
15	1	101-2076	U-BOLT	60	4	09-5725	NUT, NYLOCK, 1-8 NC
16	1	101-1749	LEVER WELDMENT, MANUAL SHIFT,	61	1	02-1016	SCREW, SHOULDER, SOCKET HEAD, 5/8, 3 1/4, STEEL, GR 8, ZINC
17	1	101-5007	WELDMENT, POST, TORQUE GAUGE	62	1	101-8607	PLATE, BASE, PRESSURE GAUGE
18	4	997-D8-160A	WELDMENT, LEG	63	6	09-5106	WASHER, SPRING LOCK, REGULAR, 3/8, 17/25, 0.035-0.125, STEEL, GR 8, ZINC
19	1	101-3596	KEYSTOCK, GEAR	64	1	10-0084	CARTRIDGE, RELIEF VALVE, 2001-2500 PSI
20	2	101-1497	TUBE, DETENT, SHIFTER	65	2	09-1042	BOLT, HEX, 3/8-16, 1/2, GR 8, ZINC, FULLY THREADED
21	2	997-0-64	SPRING, COMPRESSION	66	1	101-8625	ASSEMBLY, DOOR, 14-75K
22	2	02-0018	BALL, SHIFTING	67	2	101-8634	BUSHING, LATCH SHAFT
23	2	101-6943	ASSEMBLY, ANCHOR PIN	68	1	101-8635	SHAFT, DOOR LATCH
24	1	08-9062	VALVE, HYDRAULIC NEEDLE	69	4	09-5006	WASHER, PLAIN, FLAT, WIDE, 3/8, 1, 0.035- 0.125, STEEL, ZINC
25	1	02-9228	VALVE, CHECK	70	1	09-5119	Washer, Type A, Flat, Narrow, Preferred, 1/2, 1 5/8, 0.035-0.125, STEEL, ZINC
26	2	08-1625	CARTRIDGE, PILOT TO OPEN CHECK, LKHCDN	71	4	09-2172	1/2"-13 UNC - 1-3/4"
27	1	101-0727	MANIFOLD, HYDRAULIC, SAFETY DOOR	72	1	10-9068	FITTING, 1 1/4 MORB, 1/2 FORB, STRAIGHT
28	2	02-0981	PIN, HITCH 0.148 X 2.938				
29	1	101-5976	SHAFT, SUPPORT, ROTARY				
30	1	101-5588	TAG, RETURN				
31	1	101-5589	TAG, INLET				
32	2	02-E0186	CLAMP, PIPE, 1				
33	1	02-E0187	CLAMP, PIPE, 1 1/4				
34	2	02-E0199	CLAMP, PIPE, 2"				
35	1	101-5086	TAG, "MAKE"				
36	1	101-5087	TAG, "BREAK"				
37	1	101-6076	TAG, SHIFTER				
38	1	02-0245	GAUGE, PRESSURE, FLANGE				
39	6	09-1048	BOLT, HEX, 3/8-16, 1 1/4, GR 8, ZINC, FULLY THREADED				
40	10	09-5806	NUT, HEX, 3/8-16, STEEL, GR 8, ZINC				
41	3	09-1184	1/2"-13 UNC - 4-1/2"				
42	38	09-5110	WASHER, SPRING LOCK, REGULAR, 1/2, 43/50, 0.125-0.25, STEEL, GR 8, ZINC				
43	1	09-9124	NUT, HEX, 1/2-13, STEEL, GR 8, ZINC				
44	2	02-E0249	SCREW, CAP, SOCKET HEAD, 3/8-16, 1, ALLOY STEEL, BLACK OXIDE, WIRE LOCKABLE				
45	1	09-1007	1/4"-20 UNC - 1"				

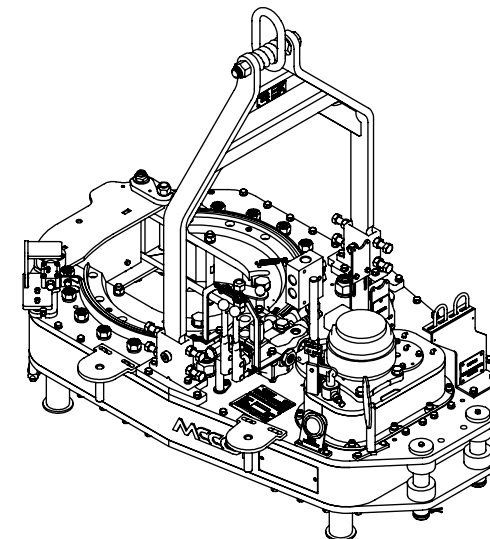

DESCRIPTION		ASSEMBLY, TONG, 14375-75K, CC	
SIZE	PART NO.	80-1001-29	REV
B			A
MATERIAL		SHEET 2 OF 2	