

ITEM	QTY	P/N	DESCRIPTION
1	1	80-1302-6	ASSEMBLY, TONG
2	1	$\triangle$ MK2050-3	MOUNTING KIT, 20-50K
3	1	BUCST21000-01	21" DP LJ TENSION BACKUP

TONG SPECIFICATION		
MAX TORQUE (FT · LBS/N · M)	50,000	67,800
ARM LENGTH (INCH/CM)	55.4	140.8
MASS (LBS/KG)	8,200	3,723
TORQUE (FT · LBS/N · M, ESTIMATED)		
AT PRESSURE (PSI/BAR):	2,500	172
Hi/Full	7,639	10,358
Lo/Full	50,000	67,800
SPEED (RPM, ESTIMATED)		
AT FLOW RATE (GPM/LPM):	60	227
Hi/Full	50.7	
Lo/Full	7.7	

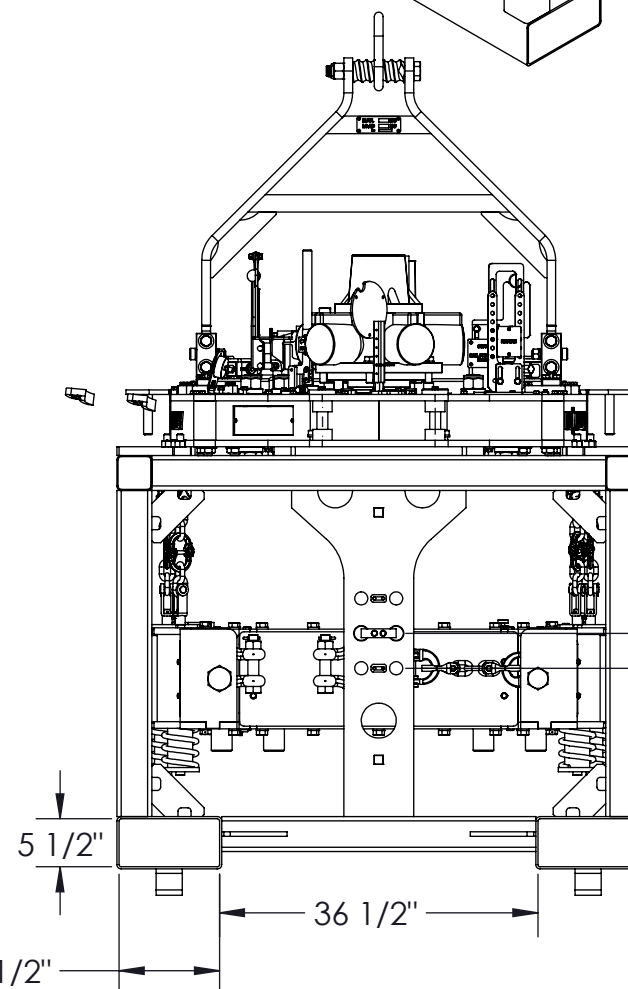
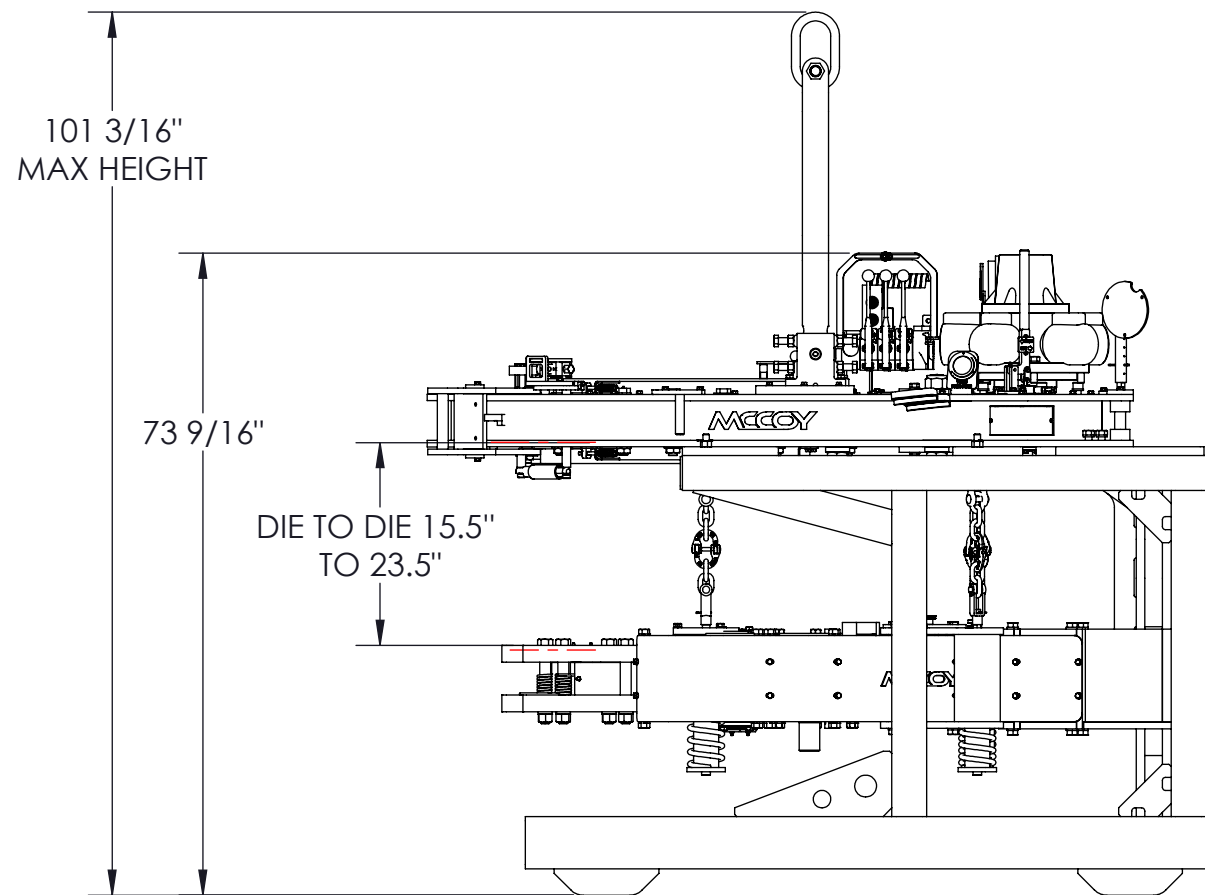

3X BACKUP MOUNTING POSITIONS @ 4.00"

RELEASED FOR PRODUCTION

REVISIONS				
REVISION	ECO NUMBER	ECO DESCRIPTION	ECO COMPLETED BY	ECO COMPLETED DATE
1	ECN002391	SEE ECN02391	S.YUAN	2/27/15
A	ECN-002520	REMOVED PARTS, MK2050-3 WAS MK2050-1, BUCST21000-01 WAS BUCST21000	S.YUAN	11/11/2015

UNLESS OTHERWISE SPECIFIED:		PROPRIETARY STATEMENT						
1. DIMENSIONS ARE IN INCHES	THIS DOCUMENT IS THE PROPERTY OF MCCOY CORPORATION AND IS CONSIDERED CONFIDENTIAL. THIS INFORMATION MAY NOT BE USED, DISCLOSED, COPIED, OR REPRODUCED IN ANY FORM, WITHOUT THE EXPRESS WRITTEN CONSENT OF MCCOY CORPORATION.							
2. TOLERANCES: ANGULAR ± 1° FRACTIONAL ± 1/16 TWO PLACE DECIMAL ± 0.02 THREE PLACE DECIMAL ± 0.005								
3. IDENTIFY P/N & MAIL P.O. USING 1/8 TO 1/4 ETCHED LETTERS; DENOTED BY "X"		DRAWN	T.YIMER	09/02/2014	DESCRIPTION ASSEMBLY, TONG, 20000-50K X 21000 LJ BU, TENSION			
4. REMOVE BURRS & SHARP EDGES WITH 1/64x45° MAX		CHECKED	B.MA	09/10/2014		SIZE PART NO.		
5. MACHINED FILET RADII SHALL BE 1/32		APPROVED	B.MA	09/10/2014		80-1310-1		
6. FINAL SURFACE ROUGHNESS AVG. (Ra) SHALL BE ≤ 250 MICROINCHES		THIRD ANGLE PROJECTION		WEIGHT	7949.9 LBS.	MATERIAL	N/A	REV A
7. DIMENSIONS IN PARENTHESES ARE CRITICAL DIMENSIONS; 100% INSPECTION REQUIRED								SHEET 1 OF 2
8. A TRIANGLE DENOTES A REVISION								
9. INTERPRET DRAWING PER ASME Y14.5-2009								

**NOTE:  
ACHIEVE "LOW", "MIDDLE", & "HIGH" BACKUP HANGING POSTIONS  
THRU ADD/REMOVE CHAIN LINKS & HAMMERLOCKS**

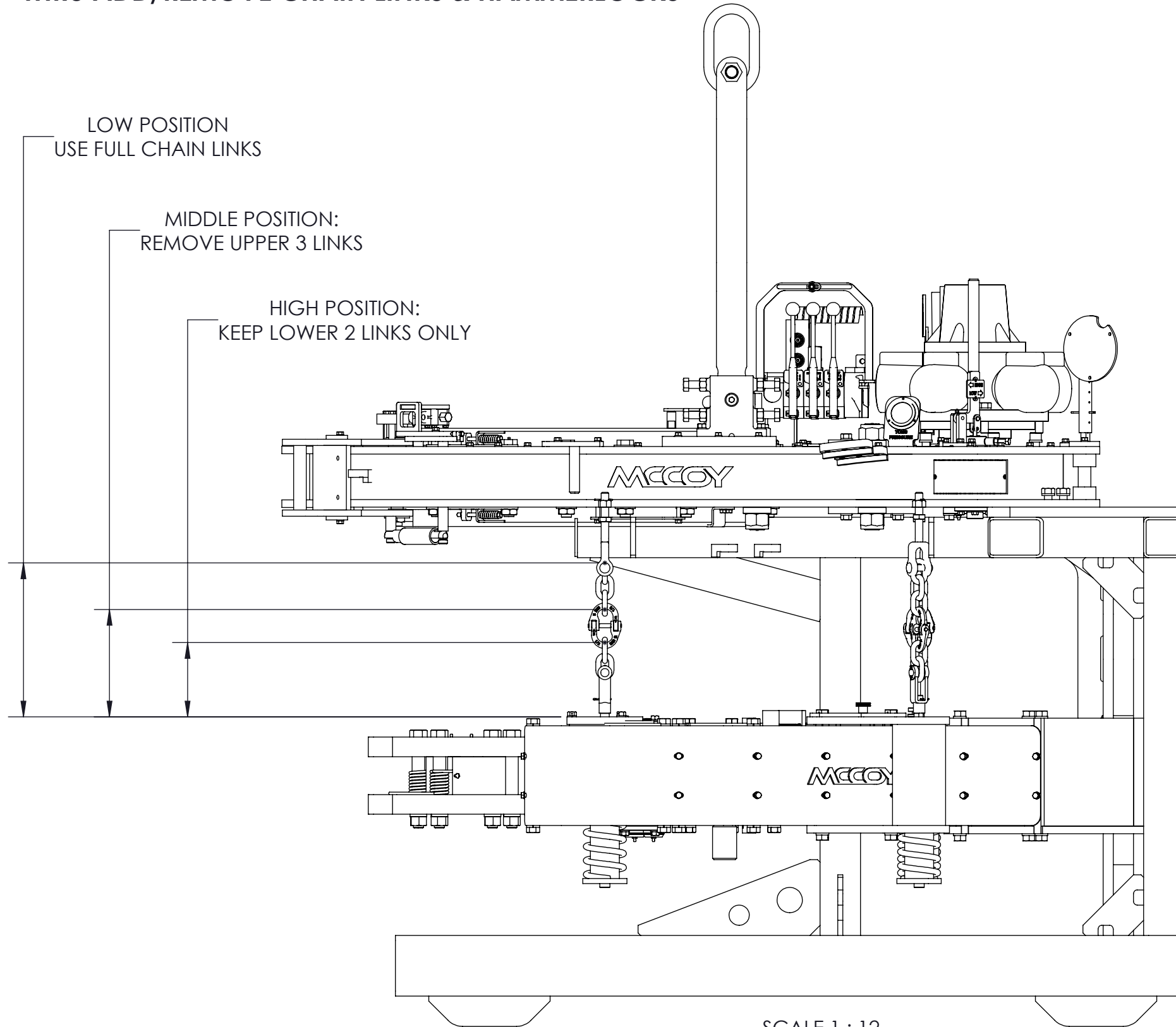

SCALE 1 : 12  
FRAMES HIDDEN FOR BETTER ILLUSTRATION



DESCRIPTION		
ASSEMBLY, TONG, 20000-50K X 21000 LJ BU,		
SIZE	PART NO.	REV
B	TENSION 80-1310-1	A
MATERIAL	N/A	SHEET 2 OF 2